

Animal-Borne Anti-Poaching System

György Kalmár
University of Szeged
Szeged, Hungary
kalmargy@inf.u-szeged.hu

George Wittemyer
Colorado State University
Fort Collins, Colorado, United States
g.wittemyer@colostate.edu

Péter Völgyesi
Vanderbilt University
Nashville, Tennessee, United States
peter.volgyesi@vanderbilt.edu

Henrik Barner Rasmussen
Savannah Tracking Ltd.
Kenya
hammersmoelf@gmail.com

Miklós Maróti
University of Szeged
Szeged, Hungary
mmaroti@math.u-szeged.hu

Ákos Lédeczi
Vanderbilt University
Nashville, Tennessee, United States
akos.ledeczi@vanderbilt.edu

ABSTRACT

Wildlife poaching is a critical driver of biodiversity loss and population decline. Poaching is a particular threat to high value, large bodied species, such as elephants, that are slow to reproduce. Increasingly, GPS tracking collars serve as a key tool for studying the behavior and monitoring wildlife globally, including application to anti-poaching efforts. However, collars provide indirect information on poaching, such as immobility, that is often not available in real time. In parallel to collar development, acoustic gunshot detection systems have proliferated in the military and law enforcement. Static systems in wildlife areas have been deployed for detecting poaching, but such systems do not scale geographically. This paper explores the idea of fusing GPS tracking collars with acoustic shockwave detectors to create an animal-borne anti-poaching sensor. A real-time alert of gunshots near elephant groups would enable rangers to respond immediately to such events. The two main technical challenges to such a system are battery life and detection accuracy. The paper presents a prototype designed for elephants that has great promise in addressing these significant technical challenges.

CCS CONCEPTS

• **Computer systems organization** → *Embedded hardware.*

KEYWORDS

wearable, acoustics, low-power, shockwave, animal conservation, poaching

ACM Reference Format:

György Kalmár, George Wittemyer, Péter Völgyesi, Henrik Barner Rasmussen, Miklós Maróti, and Ákos Lédeczi. 2019. Animal-Borne Anti-Poaching System. In *The 17th Annual International Conference on Mobile Systems, Applications, and Services (MobiSys '19)*, June 17–21, 2019, Seoul, Republic of Korea. ACM, New York, NY, USA, 12 pages. <https://doi.org/10.1145/3307334.3326080>

Permission to make digital or hard copies of all or part of this work for personal or classroom use is granted without fee provided that copies are not made or distributed for profit or commercial advantage and that copies bear this notice and the full citation on the first page. Copyrights for components of this work owned by others than ACM must be honored. Abstracting with credit is permitted. To copy otherwise, or republish, to post on servers or to redistribute to lists, requires prior specific permission and/or a fee. Request permissions from permissions@acm.org.

MobiSys '19, June 17–21, 2019, Seoul, Republic of Korea

© 2019 Association for Computing Machinery.

ACM ISBN 978-1-4503-6661-8/19/06...\$15.00

<https://doi.org/10.1145/3307334.3326080>

1 INTRODUCTION

Poaching is one of the primary drivers of wildlife decline, notoriously being listed among the top five drivers of biodiversity loss [2]. While it targets a vast array of animals, the highest valued are increasingly large-bodied, charismatic species that are particularly susceptible to overharvest due to their slow rate of population growth. The impact extends beyond the demise of the targeted species. Poaching caused wildlife declines can have serious implications for ecosystems, where the removal of animals from illegal harvest can have cascading effects on other species and even productivity of the system as a whole [3]. Poaching also can have serious social repercussions on the people living near hotspots. Recent work suggests the illegal harvest of charismatic species can have significant economic costs by compromising the potential for tourism-based revenue generation [11].

Poaching is, by definition, illegal. As such, interventions to reduce it typically follow classic law enforcement approaches. However, wildlife poaching tends to occur in remote areas, with low human densities, where detection is difficult. In addition, poaching of large, high-value species is militarized and can be driven by global crime syndicates. As such, local wildlife agents can be operationally overwhelmed, not only in terms of law enforcement equipment, but often due to the limited capacity to monitor widely and diffusely distributed animals. The development of technologies designed to overcome the challenges of remote wildlife protection that can enhance protective efficacy is needed.

Animal-borne sensors, particularly GPS-equipped collars, are used to enhance real-time wildlife protection [25]. Tracking technology offers near real-time access to the location of animals and sensor data collected on the collar. In addition, GPS tracking has become a key approach in wildlife conservation efforts focused on resolving broad landscape management issues [29]. As a result, the application of radio collars on species is becoming one of the most common tools for wildlife monitoring in ecology and conservation and used on a variety of species across numerous systems [7]. Innovations that can be integrated into tracking systems can immediately scale, offering broad application. GPS tracking is currently integrated with many anti-poaching systems, but primarily as a means to deploy assets in the vicinity of at risk individuals, though interest in using movement data to identify exposure to risk is increasing [26]. While these data streams have been valuable to resolve a number of conservation challenges, these systems have not been particularly effective in identifying poaching in real-time [15].

Detecting poaching events, be they successful or attempted, is a critical need to provide actionable information for law enforcement.

The paper presents a novel approach to anti-poaching: a ballistic shockwave detector integrated into an existing GPS collar to provide real-time alert of shots fired near the protected animal. Note that the objective is not to prevent the current poaching, but to notify the authorities so that they can apprehend the perpetrators and prevent future attempts. The work focuses on the two main technical challenges: power consumption and gunshot classification accuracy. The device needs to last two years on a single charge while continuously listening for shots. Note that no current energy harvesting technology is applicable due to the rough conditions. Law enforcement response in remote areas are extremely resource intensive, so false detections must be kept at an absolute minimum.

The rest of the paper is organized as follows. First, we present relevant related work followed by a summary of the approach we have taken. Next we briefly describe the existing commercial GPS collar we have expanded with shot detection capability followed by a description of the mechanical modifications necessary to accommodate a hole for the microphone. Section 6 presents the key idea of the work, the wake-up mechanism. Section 7 introduces the overall system architecture followed by the details of the gunshot detection and classification algorithms. Finally, the evaluation of the results are presented.

2 RELATED WORK

The use of sensors to identify security risks to animals represents a key opportunity that can advance wildlife protection, particularly in remote areas where standard anti-poaching techniques are challenged. Currently, the use of on-animal tracking systems for identifying mortality events has largely relied on beacon based signals which identify immobility after an extended period (usually 24 hours) [22] or clustering algorithms of locations to identify unnatural immobility. Once these indicators have been signaled and detected, the location can be investigated to assess if a poaching event happened. However, animals may sleep for hours and the transmission of GPS data can be delayed depending on the schedule of the collar. The delay offered by clustering or beacon based identification of immobility often means the detection of the security event is outside of an effective operational window. This limits their utility for direct intervention.

Increasing interest in sensors designed to detect immediate events is driving the development of multiple add-ons to tracking systems [22, 28]. These sensor-based approaches offer unique insight into behaviors of interest but tend to have limitations that inhibit their utility for anti-poaching solutions. Biophysical monitors are promising, but often require invasive approaches (e.g., surgical implants) and have limited lifespans. More commonly, activity sensors, such as accelerometers, are being employed to provide fine-scale information on the status and activity of a tagged individual [13, 19, 28]. However, the use of accelerometer data as a means to detect mortality has proven difficult, given that behavioral identification using accelerometers is prone to false positives.

In addition to animal-borne sensors, there are several developments in software platforms to enable the real-time visualization,

analysis, and dissemination of sensor-based data. For instance, real-time interaction with GPS tracking data has been greatly facilitated by the development of tracking apps, that can relay near real-time information to field personnel. Several tracking projects are currently using such visualization platforms as the foundation for their security operations, offering sound operational capacity for the integration of new sensor packages [25].

2.1 Gunshot Detection

There are two acoustic events associated with firing a typical rifle. The muzzle blast originates at the gun itself and spreads spherically at the speed of sound. It is the result of the propellant of the ammunition exploding inside the barrel of the gun. The second event is called the ballistic shockwave and it is caused by the bullet travelling faster than the speed of sound. This sonic boom creates a conical waveform whose tip is the bullet and that expands at the speed of sound. Both of these events can be picked up by a microphone.

A muzzle blast is a high energy event characterized by a rapid rise. However, the signal shape depends on the rifle and ammunition used and is greatly affected by the environment due to echoes. Also, the source of the muzzle blast is the gun which can be quite far from the animal. Finally, the sound energy and, hence, the detection range of the muzzle blast can be significantly lowered by a suppressor. For all these reasons, the muzzle blast is not an ideal signal for an anti-poaching sensor.

In contrast, the ballistic shockwave is a unique acoustic phenomenon (Fig. 1). Its shape in the time domain resembles a capital *N* with sub-microsecond rise time and a length of a few hundred microseconds depending on the caliber, speed, and miss distance, that is, the distance between the sensor and the trajectory of the supersonic projectile [27]. It is also a high-energy event, especially at a short miss distance. As such, it requires microphones with low sensitivity, but with a superb high frequency response. The further the microphone is from the trajectory, the more the *N*-shape of the signal gets distorted by the air acting as a low pass filter. As such, the effective and reliable detection range of the shockwave is about 50 meters. However, the miss distance will be small for poachers that are shooting at an animal and, therefore, the sensor. Given that the source of the acoustic event, the projectile, will be closer to the sensor than the gun, the samples recording the shockwave will precede those of the muzzle blast when arriving at the microphone.

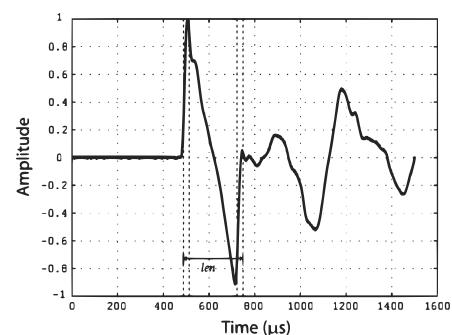

Figure 1: Shockwave of an M16 projectile

Finally, only subsonic rifles can produce projectiles that do not generate a shockwave, but their effective range is much shorter than those of regular rifles making them less commonly used for poaching. Two widely used poaching rifles are the AK-47 and the M16 (or its civilian variant, the AR15) due to their proliferation around the world. Both are supersonic, as are almost all big game hunting rifles. All of these characteristics make the shockwave the ideal target signal for an animal-borne gunshot detector.

2.2 Acoustic anti-poaching systems

There has been at least one attempt to employ a commercial gunshot detection system for anti-poaching. ShotSpotter [17] has been in use in various U.S. cities to alert police to the location of gunshots. In 2014 a small system of a few sensors was tested in Kruger National Park to detect and localize muzzle blasts related to rhino poaching. The sensors were deployed at fixed locations covering a few square miles. While there is no published evaluation of the experiment in the scientific literature, it is notable that this system is not currently employed. It is probable that unreliable acoustic classification due to attenuation and distortion limit the utility of this system in large wilderness areas. To the best of our knowledge, there was no follow up after this short-term experiment.

There are acoustic wildlife monitoring systems in use across the world, which are often deployed for extended periods. Some of these are able to detect gunshots [9, 30]. Given the few hundred-meter effective detection range for muzzle blasts, and the fact that one needs three sensors to locate a point source, these systems can only protect very small geographic areas. Covering Kruger or Serengeti would require millions of sensors, which is not practical.

3 APPROACH

Current acoustic shot detectors aimed at identifying poaching events are inadequate, given they are statically deployed and rely on muzzle blasts resulting in a limited detection area. Hence, these systems do not scale geographically. An animal-borne shot detector, on the other hand, protects the animal and its herd, not an area. Furthermore, given the animal is the target, the ballistic shockwave can serve as the primary event making classification more accurate.

The aim of this work is to integrate an acoustic shockwave detector into existing GPS tracking collars. Current tracking systems tend to record the GPS positions hourly and upload those positions several times a day. However, the presented system can be event driven, such that when a gunshot is detected, it immediately sends an alert with the last recorded GPS location, then records and sends a new position. This ensures event identification should poachers destroy the unit before the recording and sending of a new GPS position. Note, that the first shot will always be aimed at the animal and not the sensor, meaning that the system cannot necessarily save the animal wearing it. Instead, the goal is for law enforcement to be able to apprehend the perpetrators and hence, prevent further poaching. It can also act as a deterrent if the poachers realize the increased risk of getting caught.

Our initial target species is elephants because they are subject to high levels of poaching across Africa and Asia, they are being tracked in numerous locations and their large size provides the fewest mechanical constraints in terms of size, hence, batteries.

However, sensors are difficult to deploy on elephants and they are rough on the collars. Consequently, the units need to last multiple years on a single charge and the enclosure needs to be very robust. In addition, false positives are a serious concern given the remote locations where elephants roam make responding to an alert resource-intensive. Hence, the false alarm rate of gunshot classification must be kept to a minimum.

Existing wearable gunshot detectors for the military only last a day or less on a single charge [12, 23]. This is because they continuously sample and process the recorded acoustic signal. They typically use multiple microphones and high sampling rate for Angle of Arrival estimation. But even a single microphone and lower sampling rates would result in an order of magnitude lower power consumption at best. A larger battery can gain another 10× improvement. The single greatest technical challenge for the anti-poaching sensor is the requirement for another order of magnitude improvement in battery life. Due to the harsh conditions and limited size, solar or mechanical energy harvesting can not address such energy requirements. Our solution employs an ultra-low-power microphone attached to the wall of the protecting box that wakes up the rest of the system using a threshold trigger. The acoustic signal is guided through a hole and a thin tube—a kind of acoustic delay line—to an electret microphone delaying it just enough so that the entire event can be captured without information loss.

The second significant challenge is the need to virtually eliminate false positive detections. Having two microphones with different characteristics is useful. But we also add an accelerometer so that possible gunshots can be correlated with changes in the motion of the animal. Fall, immobility, or a panic run after a shot candidate will increase the confidence in detection accuracy. To validate the design of the sensor and finalize the detection algorithm, the first prototype units have SD cards on-board that store 3-axis accelerometer data continuously as well as all detected acoustic events. Due to the added power consumption of data storage and in order to progress with the development at a reasonable rate, the initial deployments are expected to last only a few months. Based on the data gathered, the hardware and software of the system will be revised and finalized.

4 TRACKING COLLARS

A popular sensor model—made by Savannah Tracking [16]—has been selected as the initial platform for integration with the gunshot detector. It is already widely used on elephants and, with different collar designs, on other species in many areas of Africa and Asia. The collar itself is made from a 135 mm wide 10 mm thick cotton fibre and rubber transmission belting. The electronic board and battery are housed inside a half-moon shaped nylon casing placed on the top of the collar in a stainless-steel metal housing. Note that once ready for deployment, the sensor enclosure is filled with resin to protect the electronics from the elements. To keep this unit on top of the neck, a steel counterweight is placed under the neck which further acts as the place for connecting the belting during deployment (Fig. 2). The total collar weight is 14 kg.

Position acquisition is done using GPS localization. The intervals between the position recordings and the lengths of averaging periods can be defined by the user to balance between the accuracy and



Figure 2: Deployed tracking collar

power consumption. Positional data is transmitted at user-defined intervals, typically every 3-6 hours, to a cloud-based server via the Iridium satellite SBD service [6]. Optionally, a GSM modem can replace the satellite-based communication for deployments where cell coverage is reasonable. Up to 24 positions can be sent in a single message, hence up to hourly positions can be included in a single daily report. The communication is half-duplex, allowing the reconfiguration of parameters of the data collection schedule after collar deployment. Data access, collar reconfiguration, database management, visualization, and animated replaying of the data are all provided via a cloud-based server.

The collar contains 4 lithium D-cell batteries providing a total of 230 Wh of power. With a typical schedule of 24 GPS positions and 4 data reports per day, this will provide around 10 years of lifetime, well above the expected average physical lifespan of 2-5 years.

The collar also contains a tri-axis accelerometer collecting data at user-defined settings of 1 – 100 Hz and between 2 – 8 g sensitivity. This data is not transmitted but evaluated on board in real-time. Activity patterns suggesting unusual behaviour (multiple excessive motions spikes) or mortality (immobility) will trigger an alarm response, which contains a GPS location and the specific type of alarm triggered. Once received by the server, this alarm is forwarded via e-mail and/or text message to a collar-specific list of contacts. Hence, shortly after an animal has started behaving in an unusual way, users will be alerted automatically with a message containing the animal's current position and the type of alarm triggered. While the accelerometer data alone is prone to false positives, combining gunshot detection with motion sensing may result in a real-time and more robust poaching detection system.

5 MECHANICAL PROTECTION

Given the strength of elephants, the mechanical protection of an acoustic sensor is challenging. The protective material needs to be strong and thick to survive the required lifetime of the sensor. The

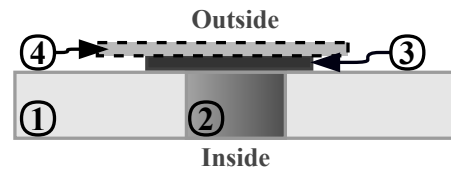

Figure 3: Structure of the acoustically permeable waterproof mechanical protection. (1) metal wall, (2) small hole, (3) waterproof acoustic vent and (4) metal mesh. The vent and the metal mesh are held in place by a metal plate bolted to the wall with a hole in the middle (not shown).

steel box, thick nylon and the resin filling offer reliable protection but also reduce the acoustic energy and the signal-to-noise ratio inside. Another undesirable effect of the rigid metal wall is the greater attenuation at higher frequencies in such dense medium [8]. The unique aspect of a shockwave is its extremely rapid rise time, which is heavily distorted by the enclosure.

To reduce these unwanted effects, a small hole is drilled into the metal wall to enable unattenuated sound propagation into the box. With this solution, the sound quality is preserved, but the waterproofness is lost. Fortunately, the same problem arises in today's handheld devices and acoustic waterproof vents with favorable sound transmission properties are readily available. These highly breathable expanded polytetrafluoroethylene membranes vibrate easily, rapidly equalize pressure, and offer protection up to IP68 [5]. The sound transmission loss is below 2dB, which is negligible. These vents are used to cover the hole, but they have a sensitive mechanical structure that needs additional protection when applied at the external surface of the box. Therefore a metal mesh with strong mechanical properties and without sound-distortion effects is used to protect the hole and the acoustically transparent venting. The final structure of the mechanical protection is shown in Fig. 3.

6 WAKE-UP MECHANISM

Gunshot detection is a pattern recognition problem that requires the constant recording and processing of environmental sounds. With wearable devices, there are trade-offs between power consumption, sensitivity and information loss. In this section, our novel wake-up mechanism is presented and compared to the state-of-the-art.

6.1 Traditional solutions

In many applications, almost constant listening can be achieved by using *analog threshold-based* wake-up circuitry to trigger recording a very short time after the acoustic event has started. Usually, the initial loss of information is negligible compared to the full length of the pattern of interest. With specialized microphones and architectures, the initial wake-up delay can be as low as 100 μ s [24], while keeping power consumption very low.

In Section 2, we explained the basics of gunshot acoustics and showed that if the listener hears the shockwave, then it must be the initial impulse-like section that reaches the microphone first. Preserving the quality, and ensuring the recording of this part of the shockwave is crucial to maximize classification accuracy. By using the previously mentioned wake-up mechanism, up to 1/3 of the N-wave pattern would be lost due to the 100 μ s initial delay. The

classical analog wake-up mechanism, therefore, cannot be used in shockwave-based gunshot detection systems.

To solve the information-loss problem, we have to take into consideration another classical solution, the *always-on listening* method. The main idea is to turn the microphone on and constantly keep pushing digitized samples into a circular buffer to maintain a short signal history in the memory. When a gunshot event happens, samples collected before the shockwave arrival are already stored in the memory enabling the recording of the full N-wave. However, this solution requires active clock sources for the microcontroller and for its peripherals. By optimizing a system for this solution, low power consumption can be achieved, but it is still significantly higher than the previously described analog mechanism.

6.2 Delay line wake-up mechanism

The combination of the ultra-low power consumption and the preservation of a full shockwave is essential in wearable gunshot sensing. To satisfy both requirements, a two-domain-based wake-up mechanism was introduced. The proposed structure is based on a kind of acoustic delay line enabling a two-phase wake-up procedure, illustrated in Fig. 4. This solution uses two types of microphones: a contact and a traditional electret microphone. The contact microphone, or pickup, is a transducer that converts the vibration of the surface it is mounted on to voltage by utilizing the piezoelectric effect. In our case, this microphone is attached to the internal side of the metal sensor enclosure. The second, traditional, microphone is placed at the end of a 3.5 cm-long tube. This tube serves as a waveguide and soundproofing for the incoming sound waves that enter the box through the protected hole.

The main idea behind this structure is to wake up the data acquisition system from deep sleep mode when the acoustic waves reach the metal wall and delay the sound waves by the tube to ensure the required amount of time for the system to prepare for data collection. This is possible since the speed of sound is negligible compared to the speed of light and the voltage generated by the contact microphone travels at the latter.

6.2.1 Timing of the wake-up procedure. The time required by the sound to travel through the tube can be calculated from the length of the tube (l) and from the speed of sound in air (c). Latter varies by the temperature, and in Africa, extreme hot weather is possible. Using reasonable limits, the propagation time, T_{prop} becomes:

$$T_{prop} = \frac{l}{c} = \frac{0.035 \text{ m}}{345 \pm 20 \text{ m/s}} = 101 \pm 7 \mu\text{s}.$$

In Fig. 4, the timing of the wake-up mechanism is presented. The shockwave arrives from the left side and propagates through the tube to reach the microphone at the end. At time point t_H , the shockwave hits the metal wall and pressure waves convert to vibration, thus voltage is being generated by the contact microphone. When the voltage level crosses the previously set threshold level, at t_W , an analog comparator wakes up the microcontroller and turns the microphone's power supply on. Our MCU needs $10 \mu\text{s}$ to wake up from deep sleep mode, so at t_C the CPU is active and enables the analog-to-digital converter (ADC). Approximately $60 \mu\text{s}$ has passed and at t_A the ADC has already collected the first digitized sample from the stabilized microphone signal. Around $40 \mu\text{s}$ later,

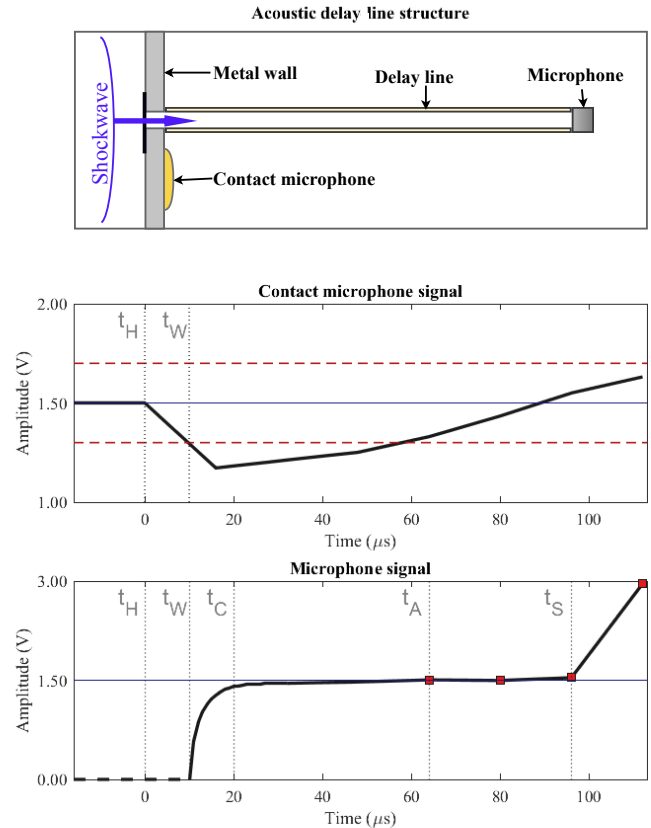

Figure 4: Details of the wake-up mechanism. In the top row the structure of the delay line and the propagation of a shockwave from left to right are shown. Below that, the microphones' signals synchronized to the shockwave's progress are plotted. Different time points of the event are marked: t_H - the shockwave hits the wall; t_W - wake-up signals are generated by the contact microphone; t_C - CPU and microphone switch to active mode; t_A - the first ADC sample is collected; t_S - the shockwave reaches the microphone.

at $t_S = t_H + T_{prop}$, the shockwave reaches the electret microphone and the leading edge is captured.

6.2.2 Advantages of the proposed mechanism. In the delay line-based structure, the power consumption before the wake-up event is very low, since only the contact microphone is active, which doesn't consume any energy. Instead, it generates voltage. Additional elements like an amplifier and comparators are needed, but ultra-low power parts are available. The gunshot detection system can spend most of the time in deep sleep mode and even the electret microphone is turned off during the listening periods. This property offers a very long lifetime to the detection system.

In addition, the delay line also enables data acquisition without information loss. This has a big positive impact on the detection accuracy as it will be presented in Section 9. When the system starts sampling, it perceives a short section of the signal's history, which happened in the past, before the wake-up event.

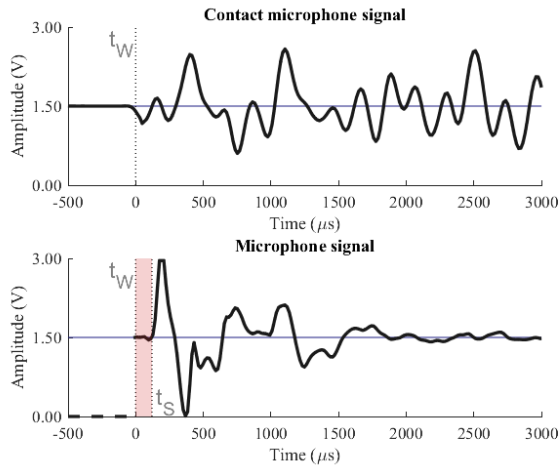

Figure 5: Gunshot recorded with the acoustic delay line wake-up mechanism. The shockwave woke up the system at time point t_W , and reached the microphone at t_S . The shaded delay region between the two events is provided by the acoustic delay line.

A gunshot event recorded with the delay line structure is presented in Fig. 5. The shaded region marks the delay between the wake-up event t_W and the arrival of the shockwave at the microphone t_S . This delay period between the two events is minimal when the position of the shockwave impact point coincides with the location of the drilled hole in the wall, that is, when the projectile trajectory is on the same side of the box as the hole. If the shockwave hits the box from other directions, the delay becomes longer, since the speed of sound in steel is over $10\times$ higher than in air, causing the vibration to reach the contact microphone almost immediately, while the sound propagating in the air needs more time to get to the hole around the enclosure.

Note that using only the low-power contact microphone alone is not an option since it would still miss the beginning of the shockwave. Moreover, the vibration of the metal wall that it measures does not preserve the characteristics of the shockwave as can be seen in Fig. 5. Mechanical impacts on the sensor enclosure generate similar signals. Also, the two signals with different characteristics are of great help in gunshot classification. See Section 8.

6.2.3 Comparison with active listening. The fast processing of the recorded signals requires significant amount of energy in any solutions. However, it is completed in only a few hundreds of milliseconds in the case of short, impulsive gunshot events. Therefore, even at high event frequencies like 1 event/minute, the total consumption is dominated by the low-power listening mode.

During the listening period, the delay line wake-up structure only runs an amplifier and two analog comparators as the main actively energy consuming parts. In contrast, the active listening method constantly requires enabled clock sources, active MCU and analog-to-digital converter, turned on microphone and amplifier. Both approaches were implemented with the same ultra-low-power hardware components, and the corresponding power consumption

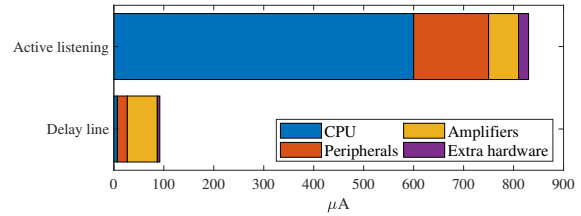

Figure 6: Power consumption comparison of the active listening and delay line wake-up methods.

values were measured in the listening phase. The delay line structure needed $102\ \mu A$, and the active listening method required $832\ \mu A$. The detailed comparison of the two mechanisms' consumption is illustrated in Fig. 6.

The significantly lower power consumption of our approach offers $8\times$ longer lifetime, or the same lifespan with batteries having significantly smaller size. A lighter and more compact sensor makes the approach feasible for smaller animals too.

The downside is some distortion of the acoustic signal caused by the tube. This effect was analyzed in the frequency domain by using chirp excitation signals. In these harmonic cases, we experienced some distortions at multiple frequencies due to resonance and standing waves in the tube. However, with real-world gunshot tests and using an external reference microphone as a baseline, we didn't experience noticeable impact on the shockwave signal shape.

The idea of using an acoustic delay line does not necessarily imply the utilization of a contact microphone. In our case, it ensures even lower power consumption and enhanced detection accuracy (explained in Section 8), but other applications may use different structures. For example, using an ultra-low-power traditional microphone as the wake-up source instead of the contact microphone is also possible. Furthermore, longer delay lines allow access to a longer history of the signal prior to the wake-up event, so less impulse-like patterns can be recorded too.

7 SYSTEM ARCHITECTURE

In this section, the hardware architecture and the most important software components are presented. A small, low-power sensor board was designed to capture, process and optionally store the acoustic signals. The developed software controls the timing of the wake-up mechanism and performs gunshot classification.

The low-power gunshot detector subsystem presented here is integrated with an existing tracking collar. The connection between the two systems is a simple two-wire protocol that can transmit alerts along with a few parameters such as confidence level. The reason for the simplest possible interface is to minimize any hardware or software modifications of the existing collar system. Once a collar is deployed, it is very difficult and resource-intensive to retrieve. Furthermore, tranquilizing an animal is a traumatic experience, so it must be avoided unless absolutely necessary. Neither is over the air firmware upgrade possible due to the low bandwidth communication channel. Once deployed, the collar must work. Therefore, any modifications carry significant risks. The currently utilized collar already has an interface for plug-and-play extension with additional sensors providing alerts. Therefore, it did not require any modifications to add the gunshot detector.

7.1 Hardware components

To implement the low-power delay line-based acoustic monitoring approach, a sensor board has been developed. Fig. 7.a summarizes the main components of the system. As it was explained earlier, the wake-up mechanism utilizes two microphones. Each microphone uses an amplifier for signal conditioning (biasing and amplification). The contact microphone's signal is connected to the MCU and to the power management subsystem, shown separately in Fig. 7.b. When the contact microphone signal leaves the interval defined by the window comparator, a logic level wake-up signal is generated. This signal is connected to the MCU, to wake it up through an interrupt, and to an SR-latch that stores the state of the power manager. The SR-latch controls a high-side switch, which, in active state, turns the electret microphone on. With this solution, the wake-up process is faster, because the MCU and the microphone are turned on at the same time. When the acoustic event recording phase is over, the MCU can reset the power manager's state (inactive microphone). Based on the detector output, the signal buffer can be saved on an SD card in the form of an audio file. The sensor board contains an accelerometer, which can be used to the monitoring the animal's movements after a potential gunshot detection. A panic-run, fall or total absence of motion can reinforce the previously sent alert.

An interesting problem occurred with the fast wake-up of the microphone. Traditional analog microphone signal conditioning circuits utilize capacitors for DC component removal before the biasing and amplification step. This capacitor needs to be charged before normal functionality is provided. The charging time of the capacitor limits the stabilization time of the microphone signal as the charging current is limited by the impedance of the feedback resistors in the amplification phase. To overcome this limitation, an active boosting circuit was used that opens a low impedance route to the capacitor in the first 40 μ s of the wake-up procedure. During this period the capacitor is being charged quickly.

The size of the existing box is limited and our sensor board needs to be attached to the wall. Therefore, a compact microphone and sensor board holder unit was designed, which can be 3D printed

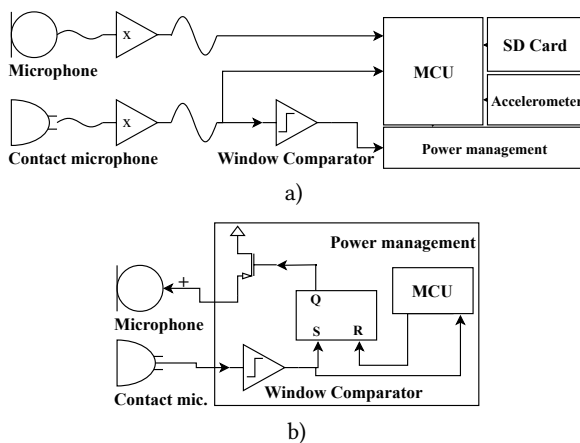

Figure 7: Hardware components of the developed board: a) abstract hardware structure, and b) details of the power management subsystem.

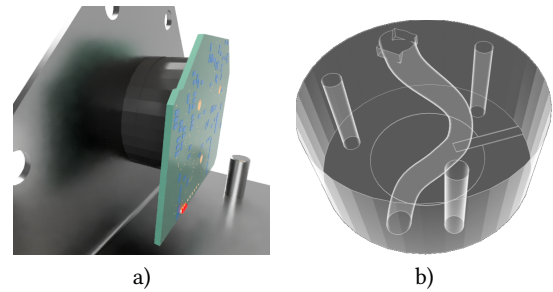

Figure 8: Illustration of the gunshot detector subsystem assembly (a). The sensor board is attached to the side of the metal wall with the help of a holder element. The curved tube inside the holder guides the sound to the microphone delaying it just enough to wake up the sensor board. The inner structure of this element can be seen in (b).

from semi-soft rubbery material instead of hard plastic. This material helps reduce the effect of the vibrations on the electret microphone. The cylinder-shaped holder has three functions. The most important one is the embedded acoustic waveguide. A 3.5 cm long, 3 mm wide tube, without any sharp turns or edges is meandering inside the holder, connecting the hole in the metal wall with the microphone. The curved tube design reduces the size of the holder to about half of the 3.5 cm tube length. The microphone is soldered directly onto the sensor board, which is fastened to the holder in such a way that the microphone penetrates the entrance of the tube. The other side of the cylinder presses the contact microphone to the metal wall. The entire structure is attached to the box with machine screws that are sealed for waterproofing. See Fig. 8.

7.2 Software components

The two most important tasks of the sensor are rapid wake-up and reliable gunshot detection. Once deployed, the system cannot be restarted or updated and must provide continuous listening for multiple years. Reliability, real-time response and power-awareness are common criteria in embedded systems, so well-known methods exist to support the development process.

The sensor board contains an STM32 Cortex M4-based microcontroller [21]. The peripherals were configured and the initialization code was generated by the STM32CubeMX software [20]. Only hardware abstraction layer (*STM32Cube HAL*) functions were used, which offer enhanced code reliability with acceptable run time overhead.

The developed firmware is an event-driven application that controls the wake-up logic, records the two microphones' signals at 66 KSPS sampling rate, runs the processing algorithm and sends alerts if needed. Some extra functionalities were added to the initial prototype: recording the acoustic events and continuous streaming of 12.5 Hz accelerometer data, both to the SD card.

8 GUNSHOT DETECTION

When an acoustic event happens, the system starts recording it within 100 μ s and a fast, nearly real-time decision is needed, because the risk of sensor damage is very high as poachers may try to destroy the device. Therefore, processing time must be limited mandating

the use of simple algorithms. The resource-constrained embedded platform also points in the same direction.

In Section 2, it was mentioned that a common rifle used by poachers is the AK-47, which has a 600 rounds/minute nominal rate of fire. It means that in every 100 ms a gunshot event can happen. The supersonic speed of the projectile causes a separation between the arrival of the shockwave and the muzzle blast at the sensor. This period can easily exceed 100 ms from reasonable ranges. This may cause an overlap of the shockwave of the second and subsequent shots and muzzle blasts at the listener's position. However, the first shockwave is almost always the first to arrive with no overlapping muzzle blast. (The only exception is when we are shooting away from the sensor and the source of both the shockwave and the muzzle blast becomes the gun itself.) We chose to record a 120 ms long period and tried to simplify the recognition algorithm to minimize the processing time.

Note that signals are only analyzed in the time domain. Resource-intensive methods based on correlation or more sophisticated techniques [1, 4, 10, 14] would be not feasible on our constrained platform because of time, memory and energy limits. Other shot detector systems used similar design decisions in the past [18].

8.1 Structure of the detector

Our gunshot detector has 3 stages. The first stage runs in real-time, and its main functionality is to filter out false wake-up events. If the microphone samples collected in the first 3 ms after the wake-up are all below a threshold value, the system stops recording and goes back to deep sleep mode. Below this threshold value, the recorded amplitudes are so small that no reliable detection is possible.

The second stage implements a cross-domain filtering and only runs offline. The main functionality is to filter out acoustic events caused by mechanical impacts on the box. Basically two types of events are possible. The first type is produced by sound pressure waves; the second is generated by mechanical impacts. The main difference between the two is the sound pressure level (SPL) and vibration energy ratio. The electret microphone converts only the sound waves into voltage difference, while the contact microphone reacts to the vibration of the metal wall. When something hits the box, a branch of a tree, water, rocks, etc., it generates significant vibrational energy compared to the energy that is generated by the corresponding sound pressure waves. In summary, when a mechanical impact happens, the contact microphone's signal gets clipped while the generated acoustic SPL remains low, resulting in small amplitudes in the electret microphone signal. In contrast, when an acoustic wave reaches the device, only a small portion of the energy is converted to vibration resulting in small amplitudes in the piezo microphone signal. However, the electret microphone signal will be pronounced. It may even clip when a high SPL wave reaches the sensor. Based on these observations, knocks can be filtered out efficiently, which is important, because these types of events have impulsive nature and occur frequently in the wild.

The third stage implements the most complex analysis. During the recording phase, preprocessed signal buffers are created, and a number of features are computed from them representing basic relations between several well-defined points of the N-wave pattern.

8.2 Shockwave detection

Gunshot detection mainly relies on shockwave classification in the system. During the recording phase, an online algorithm is constantly searching for possible shockwave candidates. It is done by finding consecutive jumps and zero-crosses in the signal and only sections with proper lengths are inserted into a candidate list. Later, only these candidate regions are analyzed, which reduces the processing time.

Fig. 9 shows a possible shockwave candidate region which has a proper length, mandating further analysis. The procedure starts by finding key points in the pattern, namely the start, the maximum, the middle, the minimum and the end points of a hypothetical N-wave shape. These points are also illustrated in Fig. 9.

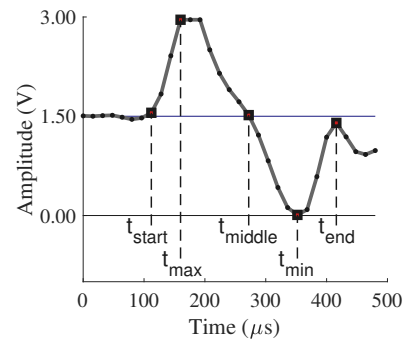

Figure 9: Shockwave candidate with marked key points.

Based on the well-known shape and symmetry of the shockwave, 10 features are calculated. Let us denote the raw microphone signal by s , a discrete-time signal with the i^{th} sample accessed by $s[i]$. s_0 denotes the same signal after bias level component removal. s_{lin} is the linearized version of s , the result of connecting the key points with straight lines. \hat{t}_{min} denotes the estimated location of the minimum point based only on the first half of the shockwave pattern. Table 1 presents the 10 extracted features.

As it will be explained in Section 9, a set of shooting range tests were carried out during the development of the algorithm. We used these recordings and our experience to define functions ϕ_i , $i = 1, \dots, 10$, which assign $[0,1]$ real-valued numbers to the extracted features f_i , $i = 1, \dots, 10$. The types and parameters of the ϕ_i functions were partially determined by analyzing the distributions of the f_i features in the collected recording set. These functions are similar to the membership functions in the field of Fuzzy theory. However, we do not use rules and the Fuzzy operators, instead a simple aggregation function, σ is defined. The σ function computes the weighted sum of the feature vector $F = [\phi_i(f_i)]_{i=1, \dots, 10}$ with a weighting vector $W = [w_i]_{i=1, \dots, 10}$, where w_i is the importance of the corresponding feature f_i . The sum of the w_i weights must be equal to 1.0. In that case the σ function produces a score between 0.0 and 1.0, which reflects the "shockwaveness" of the analyzed signal section. In the current implementation, weights were tuned accordingly to emphasize the importance of the initial section of the N-wave pattern as the end region might be affected by distortions.

Table 1: Extracted features $f_i, i = 1, \dots, 10$ from the shockwave candidates. These features are based on the known shape and symmetries of the N-wave pattern.

$Maximum\ amplitude = \max\{ s_0[t_{max}] , s_0[t_{min}] \}$
$Symmetry_T = (t_{end} - t_{middle}) - (t_{middle} - t_{start}) $
$Symmetry_{Energy} = \sum_{i=t_{start}}^{t_{end}} s_0[i]$
$Rising\ time_{Start} = t_{max} - t_{start}$
$Linearity_{\{max, middle\}} = \sum_{i=t_{max}}^{t_{middle}} s[i] - s_{lin}[i] $
$Linearity_{\{middle, min\}} = \sum_{i=t_{middle}}^{t_{min}} s[i] - s_{lin}[i] $
$Minimum\ point\ error = t_{min} - \hat{t}_{min} $
$Clipping = \#\ of\ clipped\ points$
$Rising\ time_{End} = t_{end} - t_{min}$
$Amplitude\ symmetry = s_0[t_{max}] - s_0[t_{min}] $

8.3 Muzzle blast detection and filtering

In contrast to the unique-shaped shockwave pattern, the muzzle blast does not possess any accurately distinguishable signal shape. Different rifles generate different muzzle blast signatures, which depend on many parameters of the barrel, the cartridge and the acoustic environment. With suppressors, the loud, impulsive nature of the sound can be distorted too. Therefore, our system does not rely on the detection of these acoustic events, but may use the information for additional confirmation. The implemented muzzle blast detector analyzes the recorded signal in the time and energy domain. The time domain analysis uses the impulsive nature and loudness of the blast and filters out false patterns by their length. The energy domain detection tries to examine the same, corresponding features. In both domains, only inaccurate recognition is possible, but if both of the methods mark the same section of the signal as muzzle blast region, then the system interprets this as a possible muzzle blast candidate, which may lead to a final decision with higher confidence.

The structure of the entire recording is also analyzed by a filtering component. For example, if the recording contains a high SPL, but periodic, long lasting signal and a less perfect shockwave pattern close to the end, it is probably a false detection. In contrast, if a less reliable shockwave detection occurs at the very beginning of the recording and a weak muzzle blast detection also occurs later, it is likely that a gunshot event happened. A set of similar intuitive rules have been implemented to strengthen or weaken the detection outcomes.

8.4 Final aggregation and examples

The three separate components in the third stage of the gunshot detector (shockwave detection, muzzle blast detection and filtering) all produce a [0,1] real-valued outcome. These values are combined into one final output, which reflects the probability of a gunshot event. The aggregation emphasizes the importance of the shockwave detection result. However, if the filtering method rejects the recording based on the mentioned intuitive rules, the aggregation

is bypassed and the final output becomes 0.0 without the execution of the additional detection algorithms.

The use of soft computing has a benefit of postponing critical decisions to the later stages. In our case, it means that a confidence level can be attached to the gunshot alert and the anti-poaching team can take it into consideration as well as various other factors before a response is initiated. Therefore, our approach is to set a threshold only for alert sending and never make a strict decision about events. The alert sending threshold is not finalized in the current state of development yet; the fine tuning of this part of the system will happen after the completion of the ongoing wildlife tests in Africa (see Section 9).

In Fig. 10 a set of examples can be seen; the recording of a knock, an animal sound and a gunshot. It also illustrates the basic structure and behavior of the detector, where the recordings propagate through the stages. In all three cases, the upper signals correspond to the contact microphone, the lower signals to the electret microphone. All of the recordings contain active acoustical events, so Stage 1 lets them through. Stage 2 filters out mechanical impact events, and as it can be observed, the vibrational energy is overwhelming compared to the acoustical energy in the leftmost recording. This ratio between the energies suggest that a physical contact event happened and this recording does not reach the next phase. The two acoustical events are processed by the final stage, where probabilities are assigned to each recording. In the case of the animal sound, the recording does not contain impulsive sections, just periodic pattern, so the filtering method of this stage rejects this signal and interrupts the execution of further detection algorithms. The rightmost example is a true gunshot, therefore, shockwave and muzzle blast detection happen and the filtering method confirms it by analyzing the whole recording. The output vector is aggregated from these three values and an alert message is sent with a high confidence that a gunshot occurred.

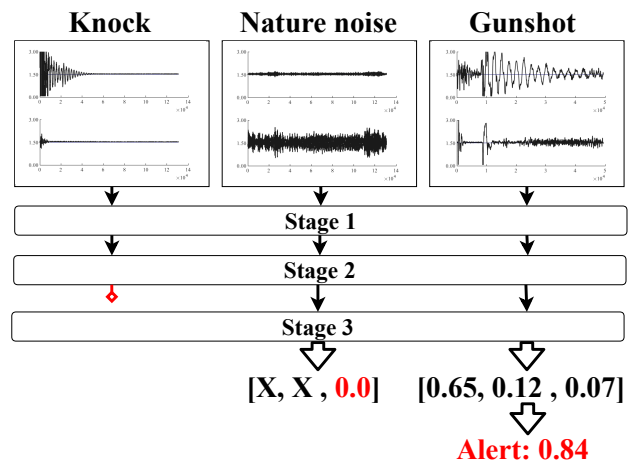

Figure 10: The structure and the behavior of the detector with three example recordings propagating through the stages. In these recordings on the top, the upper signals correspond to the contact microphone, the lower ones to the electret microphone.

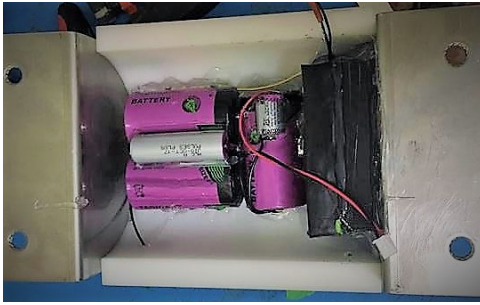

Figure 11: Commercial GPS tracking unit extended with the gunshot detection subsystem before being filled with resin. The protective black box contains the acoustic sensor board and the delay line. One of the batteries (purple cylinders) is reserved for the gunshot detector and the remaining ones for the tracking unit (located underneath). Additional supercapacitors (grey cylinders) are included to help with the current spikes of the GPS and the SD card.

9 EVALUATION

To help the development of the gunshot detection system, numerous experiments were carried out. Typically, tests were performed on the shooting range to assess and understand the nature of shock-wave propagation in different structures. The choice of materials, microphones, amplifications and the fine-tuning of the detection algorithm are all based on these field experiments.

Animal-borne tests were performed too, where we could collect real-world data, sounds, mechanical impacts, accelerometer data, etc. During the first such experiment, the device was worn by a cow for two weeks. Note that this unit did not have the GPS board and it only contained a single battery and a much lighter counterweight. The purpose of this test was to evaluate the mechanical durability of the structure, to check the robustness of basic software components and to collect real acoustic events through the delay line.

The second real-world experiment became possible with the help of the San Diego Zoo and Safari Park. During this test, elephants wore the device for two weeks. To reduce the load on any one animal, each elephant carried the box for two days at a time. A static node close to the elephant herd was also deployed. The two nodes collected environmental sounds produced by the elephants, neighboring animals and people. The boxes successfully survived the proposed two weeks and collected 7500 events.

The third and most relevant experiment is currently ongoing in Kenya, where a prototype sensor has been deployed on a wild elephant and it is collecting wildlife sounds and accelerometer data under real-world conditions. The internal assembly of the unit is presented in Fig. 11.

To evaluate the detector algorithm with representative data, a set of additional impulsive sound effects have been collected. These events included animal and natural environmental noises such as thunder and rain. The collection was played back in a sound studio and the acoustical events were re-recorded by our device. The playback was carried out by a high-end speaker with a flat frequency curve at high SPL levels. All of the produced events exceeded the 110 dB SPL level, which was verified by a measurement microphone.

These pressure levels are rare in the nature, but our wake-up mechanism, which is fine-tuned for gunshots (above 120 dB SPL), requires the presence of SPL levels above 90 dB to activate. These recordings allow the analysis of the detection algorithm separately, since most of them would be rejected by the earlier stages of the detector in their real form.

From the various animal tests and experiments, a dataset has been created. The dataset contains 1000 mechanical impact noises (collected by knocking the box with different materials), 1683 nature sounds from the sound studio experiment and 7500 events from elephants and from their environment. 71 gunshots were also recorded with the final structure of the device, which are independent from the samples that were used during the development of the gunshot detection algorithm.

9.1 Results

Each subgroup of the dataset was analyzed separately. As was explained in the previous section, the detector output represents the probability of gunshot pattern containment in the particular recording. The output values of the detection algorithm were collected into histograms, where the vertical axes are presented on a logarithmic scale, because the comparison of numbers with different magnitudes are required. The results are summarized in Fig. 12.

In the third (green) row in Fig. 12, the histogram of the 1000 outputs of the mechanical impacts subgroup is presented. It can be seen that only two inputs received small, but greater than zero probabilities. Most of the recorded signals have an impulsive nature and detection based only on the microphone signal would be challenging. However, our method uses the cross-domain filtering in the second stage of the detector, which efficiently filters out these types of events.

The results are similar in the case of nature sounds shown in the second (blue) row in Fig. 12. These acoustic events are the most challenging for the classification algorithm, since only the pattern recognition part is responsible for false positive rejection.

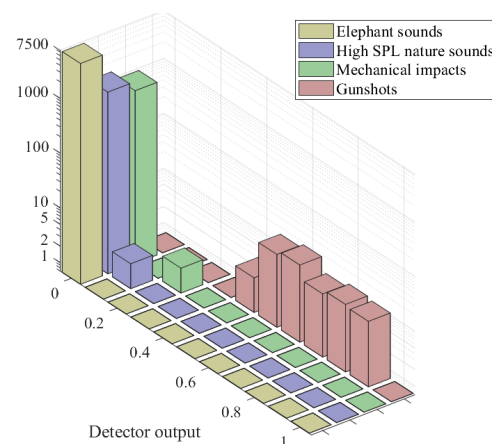

Figure 12: Output histograms of each subgroup of the dataset. A clear separation between the various sounds and gunshots can be observed. Note that all acoustic events analyzed were recorded with the actual sensor.

However, the shockwave and gunshot patterns are unique in nature, which makes the recognition problem feasible with high accuracy. Only two of the 1683 events resulted in (slightly) greater than zero shockwave confidence levels.

The first (yellow) row in Fig. 12 illustrates the accuracy of the detector, when the input data came from real elephant environment. All of the 7500 events rejected correctly, as no gunshots happened near the elephants. The result is promising, because this group of the dataset contains samples that are probably the closest to real-world wildlife sounds.

We have seen the detector's false positive rejection performance, but the main challenge is to remain sensitive to the lower quality gunshots at the same time. The last (red) row in Fig. 12 presents the result of the detection algorithm on gunshot recordings. As it can be observed, all of the samples have probabilities that are suggesting gunshot activity. On the shooting range during the tests, we varied the distance between the sensor and the rifles (AK-47 and AR15), and the orientation and distance of the box relative to the bullet trajectory. We also covered the box with mud to simulate real-world conditions. Because of these effects, the recorded shockwaves and muzzle blasts vary in quality.

During the real application of the presented device, false alarms will be expensive and immediately result in loss of trust. Therefore, the alert-sending threshold must be chosen carefully. Since our first wildlife test is currently ongoing, this functionality of the system will be fine-tuned when the data become available. However, from the analyzed dataset, the threshold value can be estimated. The maximal confidence value was 0.22 for non-gunshots, while the lowest gunshot score was 0.44. Therefore, a threshold value between these two numbers would result in 0 false positive alerts, while all of the gunshots would be reported.

9.2 Power consumption

The power measurements presented in Section 6 are based on a laboratory circuit of the acoustic channel and the microcontroller. The current operational prototype includes power regulators, the accelerometer circuitry and an SD card to save all acoustic and acceleration data to fine-tune the classification algorithms for the next version. The power consumption of this prototype board in different states was also analyzed to estimate the expected lifetime. In sleep mode, it consumes $250 \mu A$, which exceeds the value presented in Fig. 6 by $150 \mu A$ due to the additional components.

In active processing mode, the power consumption is $4.6 mA$, which is dominated by the CPU running at a high frequency. Note that the SD card was physically removed during the tests and the corresponding data logging software functions were disabled. The lengths of the active periods are dependent on the level of action required by the detector algorithm. If a false wake-up event happens, Stage 1 immediately sends the device back to sleep mode, and the active mode only lasts for $3 ms$. If the wake-up is caused by a mechanical impact or an acoustic event, the length of the signal buffer used is $120 ms$. Stage 2 relies only on features calculated online, thus its output is generated instantly and the required duration is therefore $120 ms$. If a signal reaches Stage 3, the most complex part of the detector is executed to analyze the possible shockwave and muzzle blast candidates. As the signal buffer is short (8000 samples),

and all of the methods have time complexity of $O(n)$, Stage 3 terminates rapidly. The (over)estimated maximal total time of a gunshot detection is $240 ms$.

To estimate the rate of wake-up events, we analyzed our San Diego Zoo dataset. During the two weeks of deployment, the average rate was 20 events/hour including the false wake-up cases. If we assume that all of these events reach Stage 3, and an additional 1000 false wake-up and 100 mechanical impact events happen every hour, which is a safe overestimate, the average power consumption becomes $273 \mu A$. If we double these rates (40, 2000, 200), the current draw only rises by 10% to $298 \mu A$. In the current GPS tracking collar setup, the battery dedicated to the gunshot detector subsystem has a nominal capacity of 19 Ah, which offers a lifespan of 8 years with the estimated event rates. As the proposed lifetime of a tracking collar is only 2 years, smaller batteries could be used, enabling the use on a wide variety of animals.

10 CONCLUSIONS AND FUTURE WORK

An animal-borne gunshot detection system has been developed to extend currently used GPS tracking collars for elephants. With the fusion of the two systems, gunshot alerts can be raised in real-time coupled with location data. The main challenges were the multi-year lifetime requirement, the preservation of the sound and shockwave quality and minimizing the false positive rate. With an acoustic delay line structure that utilizes two microphones with different characteristics, the power consumption has been dramatically reduced and the detection accuracy improved significantly. Real-world tests were carried out, including with elephants in a safari park. The collected dataset contained various environmental sounds, mechanical impacts and real gunshots. The evaluation of the detection algorithm on this dataset showed promising results.

The first prototype sensor with on-board storage has been integrated into a GPS tracking collar, and is currently under real wildlife testing in Africa. After several months, the collected data from this test will be available and the fine-tuning of our gunshot detection algorithm will be performed. The longer term goal of the project is to release all hardware and software in open source form so that gunshot detection capability can be freely integrated into any tracking collars.

11 ACKNOWLEDGEMENTS

We would like to thank the Vodafone Americas Foundation and their Wireless Innovation Project as well as the Vanderbilt University Discovery Grant program for supporting this research.

Ken Pence and the Nashville Police Academy provided their expertise and facilities to help with live fire testing. Megan Owen and the San Diego Zoo Safari Park assisted the project greatly by allowing the deployment of a prototype on their elephants. So did Save the Elephants and the Kenya Wildlife Service by supporting deployment of the sensor on wild elephants. György Orosz of the Budapest University of Technology and Economics suggested the active boosting circuit. We are grateful to all of them, as well as to Malu Jorge, Trina Merrick and John Fellenstein of Vanderbilt and O. L. Robertson of Murray State University for their assistance and to Mary Baker, the anonymous reviewers and our shepherd, Mark Corner for their helpful suggestions.

REFERENCES

- [1] Talal Ahmed, Momin Uppal, and Abubakr Muhammad. 2013. Improving efficiency and reliability of gunshot detection systems. In *Acoustics, Speech and Signal Processing (ICASSP), 2013 IEEE International Conference on*. IEEE, 513–517.
- [2] Bradley J. Cardinale et al. 2012. Biodiversity loss and its impact on humanity. *Nature* 486, 7401 (2012), 59.
- [3] James A. Estes et al. 2011. Trophic Downgrading of Planet Earth. *Science* 333, 6040 (2011), 301–306. <https://doi.org/10.1126/science.1205106> arXiv:<http://science.sciencemag.org/content/333/6040/301.full.pdf>
- [4] L. Gerosa, G. Valenzise, M. Tagliasacchi, F. Antonacci, and A. Sarti. 2007. Scream and gunshot detection in noisy environments. In *2007 15th European Signal Processing Conference*. 1216–1220.
- [5] GoreTex [n. d.]. Gore Portable Electronic Acoustic Vents. https://www.gore.com/sites/g/files/ypypipe116/files/2016-12/GORE_Acoustic_Vents_immersion_EN_DEC_2016.pdf. Accessed: 2018-12-03.
- [6] Iridium [n. d.]. Iridium Short Burst Data (SBD). <https://www.iridium.com/services/iridium-sbd/>. Accessed: 2018-12-11.
- [7] Roland Kays, Margaret C. Crofoot, Walter Jetz, and Martin Wikelski. 2015. Terrestrial animal tracking as an eye on life and planet. *Science* 348, 6240 (2015). <https://doi.org/10.1126/science.1254278> arXiv:<https://science.sciencemag.org/content/348/6240/aaa2478.full.pdf>
- [8] Lawrence E. Kinsler, Austin R. Frey, Alan B. Coppers, and James V. Sanders. 1999. *Fundamentals of Acoustics*. Wiley.
- [9] C. Lopez-Tello and V. Muthukumar. 2018. Classifying Acoustic Signals for Wildlife Monitoring and Poacher Detection on UAVs. In *2018 21st Euromicro Conference on Digital System Design (DSD)*. 685–690. <https://doi.org/10.1109/DSD.2018.00006>
- [10] S. Srinivasan M. R. Azimi-Sadjadi, Y. Jiang. 2007. Acoustic classification of battlefield transient events using wavelet sub-band features. *Proc.SPIE* 6562 (2007), 6562 – 6562 – 8. <https://doi.org/10.1117/12.722296>
- [11] Robin Naidoo, Brendan Fisher, Andrea Manica, and Andrew Balmford. 2016. Estimating economic losses to tourism in Africa from the illegal killing of elephants. *Nature Communications* 7 (2016). <https://doi.org/10.1038/ncomms13379>
- [12] QinetiQ [n. d.]. QinetiQ Ears gunshot localization system datasheet. https://qinetiq-na.com/wp-content/uploads/Datasheet_SWATS_LR.pdf.
- [13] Emily S Rothwell, Fred B Bercovitch, Jeff RM Andrews, and Matthew J Anderson. 2011. Estimating daily walking distance of captive African elephants using an accelerometer. *Zoo biology* 30, 5 (2011), 579–591.
- [14] Brian M Sadler, Tien Pham, and Laurel C Sadler. 1998. Optimal and wavelet-based shock wave detection and estimation. *The Journal of the Acoustical Society of America* 104, 2 (1998), 955–963.
- [15] Christie Sampson, John McEvoy, Zaw Min Oo, Aung Myo Chit, Aung Nyein Chan, David Tonkyn, Paing Soe, Melissa Songer, A. Christy Williams, Klaus Reisinger, George Wittemyer, and Peter Leimgruber. 2018. New elephant crisis in Asia—Early warning signs from Myanmar. *PLOS ONE* 13, 3 (03 2018), 1–13. <https://doi.org/10.1371/journal.pone.0194113>
- [16] SavannahTracking [n. d.]. Savannah Tracking website. <http://www.savannahtracking.com>. Accessed: 2018-12-03.
- [17] ShotSpotter [n. d.]. ShotSpotter website. <http://www.shotspotter.com/products/military.html>.
- [18] Gyula Simon, Miklós Maróti, Ákos Lédeczi, Gyorgy Balogh, Branislav Kusý, András Nádas, Gábor Pap, János Sallai, and Ken Frampton. 2004. Sensor network-based countersniper system. In *In Proc. of ACM SenSys*. ACM Press, New York, NY, USA, 1–12. <https://doi.org/10.1145/1031495.1031497>
- [19] Joseph Soltis, Rory P Wilson, Iain Douglas-Hamilton, Fritz Vollrath, Lucy E King, and Anne Savage. 2012. Accelerometers in collars identify behavioral states in captive African elephants *Loxodonta africana*. *Endangered Species Research* 18, 3 (2012), 255–263.
- [20] stm32cubemx [n. d.]. STM32Cube initialization code generator. https://www.st.com/content/st_com/en/products/development-tools/software-development-tools/stm32-software-development-tools/stm32-configurators-and-code-generators/stm32cubemx.html. Accessed: 2018-12-03.
- [21] stm32mcu [n. d.]. STM32L476RG ultra-low-power microcontroller. <https://www.st.com/en/microcontrollers/stm32l476rg.html>. Accessed: 2018-12-03.
- [22] Stanley M Tomkiewicz, Mark R Fuller, John G Kie, and Kirk K Bates. 2010. Global positioning system and associated technologies in animal behaviour and ecological research. *Philosophical Transactions of the Royal Society B: Biological Sciences* 365, 1550 (2010), 2163–2176.
- [23] Peter Volgyesi, Gyorgy Balogh, Andras Nadas, Christopher Nash, and Akos Ledeczi. 2007. Shooter Localization and Weapon Classification with Soldier-Wearable Networked Sensors. *5th International Conference on Mobile Systems, Applications, and Services (MobiSys)* (2007).
- [24] Wake-on-sound microphone [n. d.]. Wake-on-sound microphone. <http://www.puiaudio.com/product-detail.aspx?categoryId=4&partnumber=PMM-3738-VM1010-R>. Accessed: 2018-12-03.
- [25] Jake Wall, George Wittemyer, Brian Klinkenberg, and Iain Douglas-Hamilton. 2014. Novel opportunities for wildlife conservation and research with real-time monitoring. *Ecological Applications* 24, 4 (2014), 593–601. <https://doi.org/10.1890/13-1971.1>
- [26] Jake Wall, George Wittemyer, Brian Klinkenberg, and Iain Douglas-Hamilton. 2014. Novel opportunities for wildlife conservation and research with real-time monitoring. *Ecological Applications* 24 (06 2014), 593–601. <https://doi.org/10.1890/13-1971.1>
- [27] G.B. Whitham. 1952. Flow pattern of a supersonic projectile. *Communications on pure and applied mathematics* 5, 3 (1952), 301.
- [28] Christopher C. Wilmers, Barry Nickel, Caleb M. Bryce, Justine A. Smith, Rachel E. Wheat, and Veronica Yovovich. 2015. The golden age of bio-logging: how animal-borne sensors are advancing the frontiers of ecology. *Ecology* 96, 7 (2015), 1741–1753. <https://doi.org/10.1890/14-1401.1> arXiv:<https://esajournals.onlinelibrary.wiley.com/doi/pdf/10.1890/14-1401.1>
- [29] George Wittemyer, Guillaume Bastille-Rousseau, and Joseph M. Northrup. 2019. Behavioral valuation of landscapes using movement data. *Philosophical Transactions of the Royal Society B: Biological Sciences* (2019). <https://doi.org/10.1098/rstb.2015.0615> In Press.
- [30] Peter H. Wrege, Elizabeth D. Rowland, Sara Keen, and Yu Shiu. 2017. Acoustic monitoring for conservation in tropical forests: examples from forest elephants. *Methods in Ecology and Evolution* 8, 10 (2017), 1292–1301. <https://doi.org/10.1111/2041-210X.12730> arXiv:<https://besjournals.onlinelibrary.wiley.com/doi/pdf/10.1111/2041-210X.12730>